

# Assembly Manual

12 ft x 12 ft / 3.66 m x 3.66 m cosmos Pergola  
ITM. / ART. 2127018

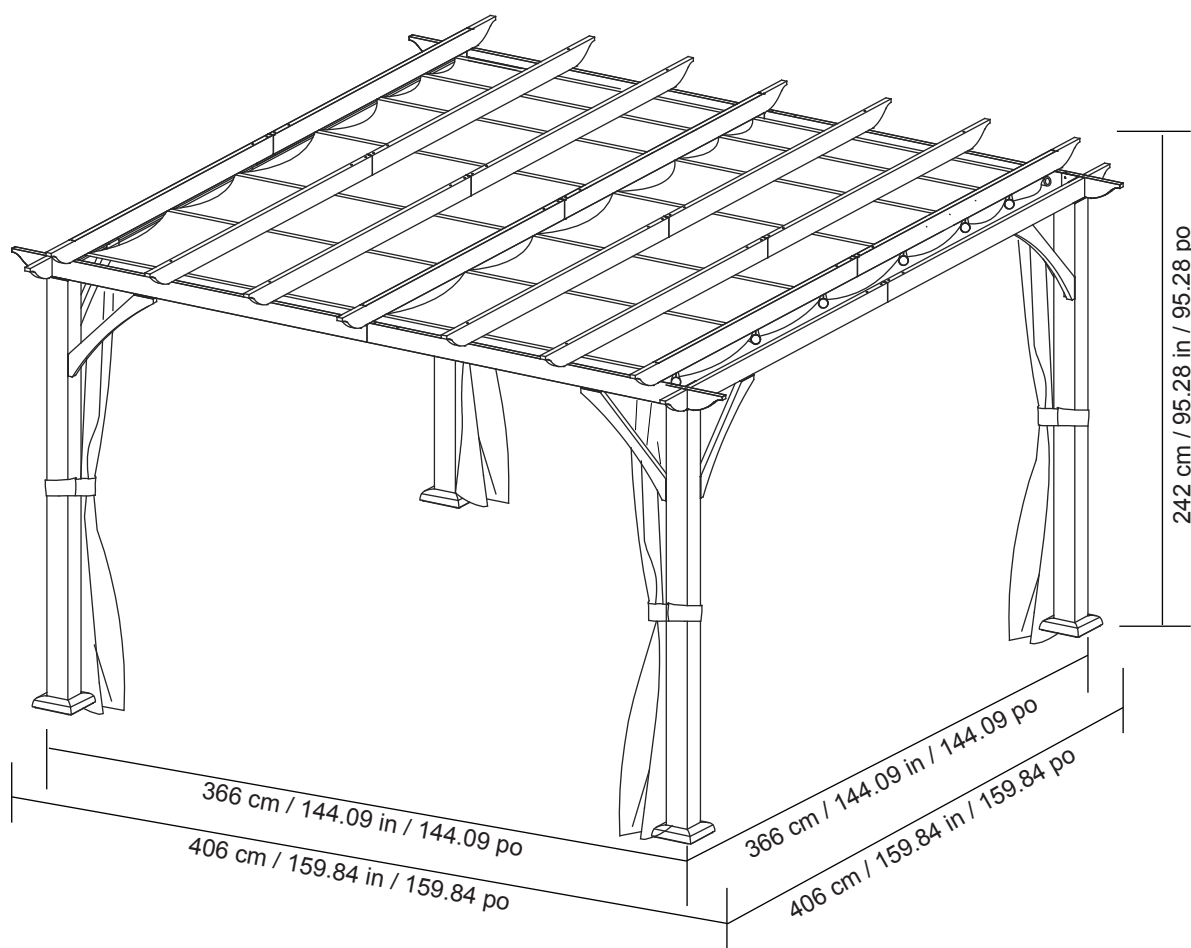

**IMPORTANT. PLEASE READ CAREFULLY AND RETAIN FOR FUTURE REFERENCE**

For Outdoor Use only. Not for Commercial Use.



If you experience any product malfunction, defect or are missing any parts, please contact our customer service department at 1-855-586-8118 or [servicec @ taipengchina.com](mailto:servicec@taipengchina.com). Our hours of operation are Monday - Friday, 8:30 AM to 5:30PM EST.

## SAFETY INFORMATION

---

For the best assembly and usage experience, please read through all steps before attempting to assemble, operate or install the product

- **WARNING:** It is the consumer's responsibility to comply with any building codes, ordinances, zoning limitations, or local homeowner's restrictions and obtain any required permit, before purchase and installation of the products.
- **WARNING:** KEEP ALL FLAME AND HEAT SOURCES AWAY FROM THIS GAZEBO FABRIC. This item meets the CPAI-84 flammability requirements. The fabric may burn if left in continuous contact with any flame source. The application of any foreign substance to the tent fabric may cause the flame-resistant properties ineffective.
- In the case of any high winds or high amounts of rain/snow, please remove the mosquito net, clear the snow from the roof immediately and check for damage before continuing use.

### CAUTION

#### SET UP YOUR GAZEBO PROPERLY

- This product is heavy so do not attempt to assemble this item alone. For the best and safest assembly experience, we recommend four (4) adults.
- Keep all children, pets and other obstructions away from assembly area.
- If any part is missing or damaged, do not attempt to assemble the product.
- In order to avoid damage to the gazebo and its components, please use the appropriate tools.
- Do not use the structure as support.
- Check all bolts on a regular basis to maintain the sturdiness and safety of the structure.
- Keep instruction manual for future use.
- Do not climb on top of the gazebo. Falling off the gazebo can result in serious injury, possibly even death.

#### EXAMINE YOUR GAZEBO

- Examine occasionally to ensure there are no loose parts.
- If loose parts are found, they should be retightened immediately.

## PREPARATION

---

Before beginning assembly of product, make sure all parts are present. Compare parts with package contents list and hardware contents list. If any part is missing or damaged, do not attempt to assemble the product.

Estimated Assembly Time: 3 hours.

Tools Required for Assembly (not included in the box):

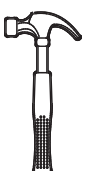

Hammer



Screwdriver



Safety goggles



Gloves



Hardhat



Stepladder

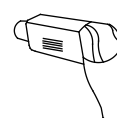









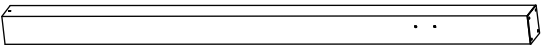
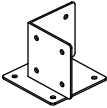







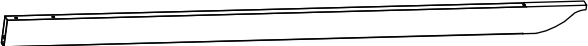
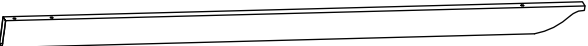

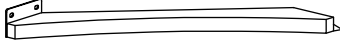
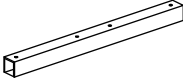
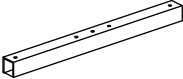

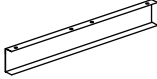
Electric drill

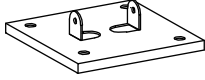
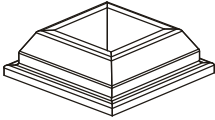

Percussion drill

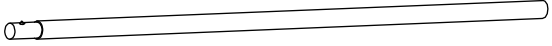
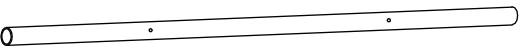

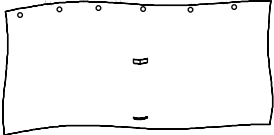
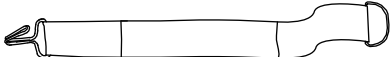



# Components

A	Post	4	
B	Post Corner	4	
C	Crossbeam Left	1	
C1	Crossbeam Right	1	
C2	Crossbeam Left	1	
C3	Crossbeam Right	1	
C4	Crossbeam Left	2	
C5	Crossbeam Right	2	
C6	Decoration Cap	4	
D	Track Beam	6	
D1	Top Crossbeam	8	
E	Left Inclined Strut	4	
E1	Right Inclined Strut	4	
F	Crossbeam Connector	14	
F1	Crossbeam Connector	2	

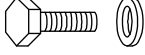
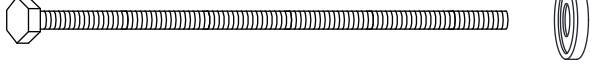
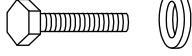
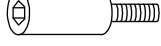
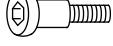
F2	Crossbeam Connector	3	
G	Top Crossbeam Shield	4	
G1	Track Beam Shield	3	
G2	Crossbeam Shield	2	
G3	Crossbeam Shield	2	
H	Base	4	
I	Base Cover	4	
J	Left Cloth-inserted Pipe	6	
J1	Right Cloth-inserted Pipe	6	
J2	Fixed Tube	2	
K	Roof	1	
L	Sidewall	4	
M	Draw Cord	1	
N	Pulley	12	

O	Pulley	6	
---	--------	---	---

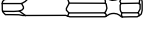
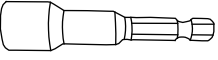
## Hardware

AA	Bolt\Flat Washer (m6*15)	164	
BB	Bolt\Plastic Washer (m6*115)	14	
CC	Bolt\Flat Washer (m6*30)	4	
DD	Bolt (m6*15)	8	
EE	Bolt (m6*15)	12	
FF	Allen Wrench	1	
GG	Hanger	48	
HH	Expansion bolt	16	
II	Allen Wrench	1	
JJ	Sleeve	1	
KK	Wrench	1	
LL	Allen Wrench	1	

# Step 1

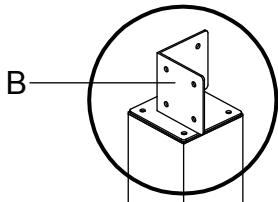
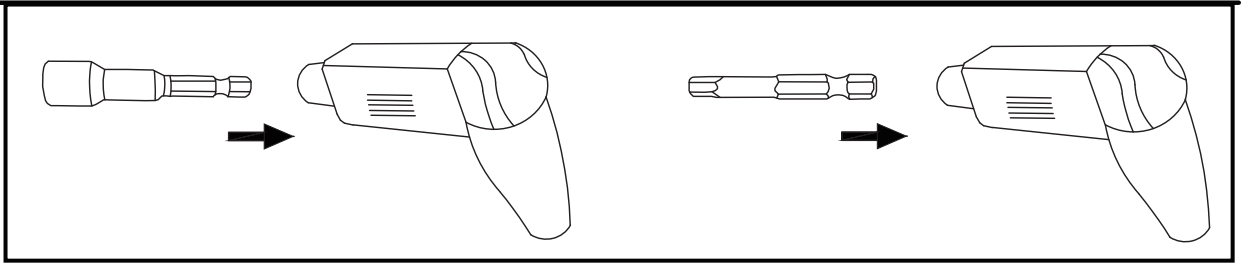

A

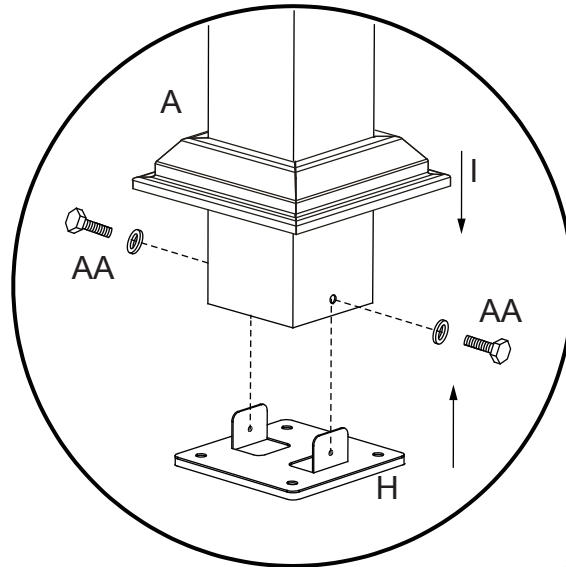

Fig 1

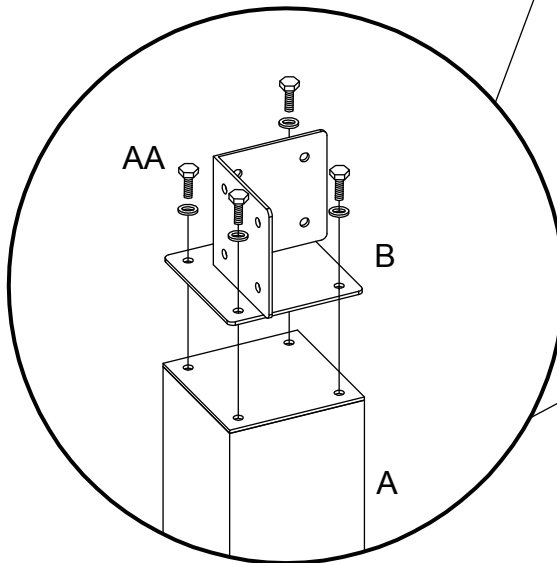
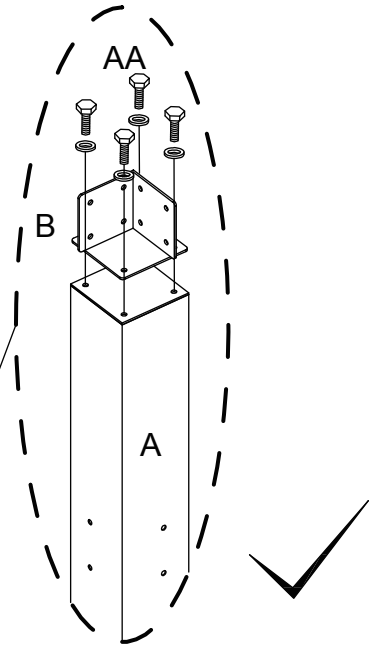
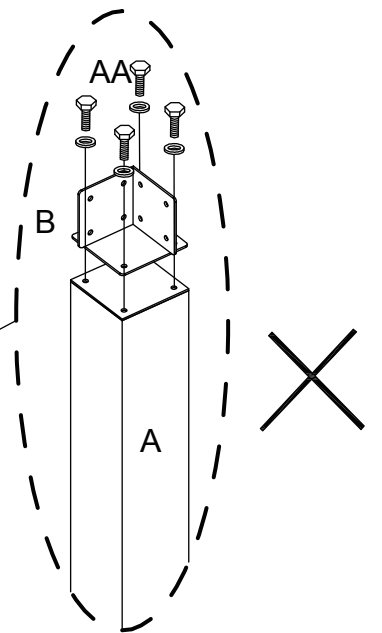
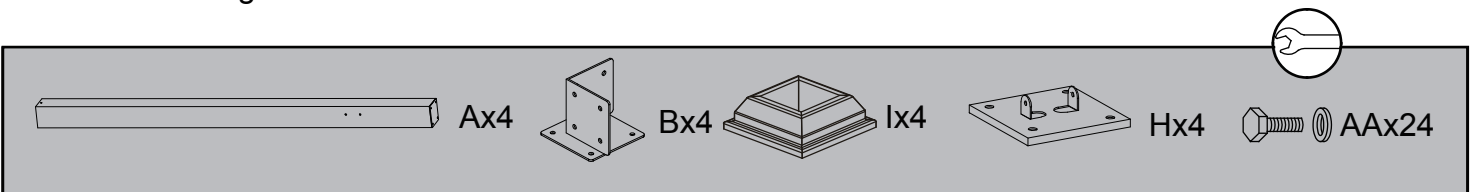

Fig 2



- 1.1. Insert the Post (A) into the Base Cover (I) and connect it to the Base (H) with Bolt (AA). See Fig 1.  
 1.2. Connect the Post Corner (B) to the Post (A) with Bolt (AA), please pay attention to the installation direction. See Fig 2.



# Step 2

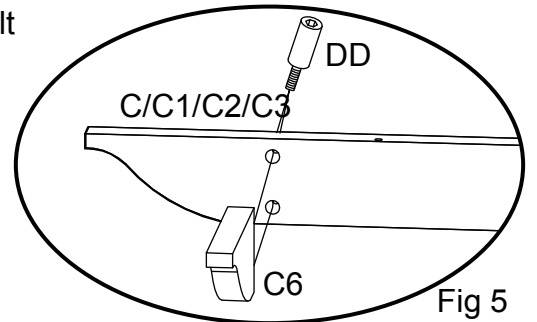
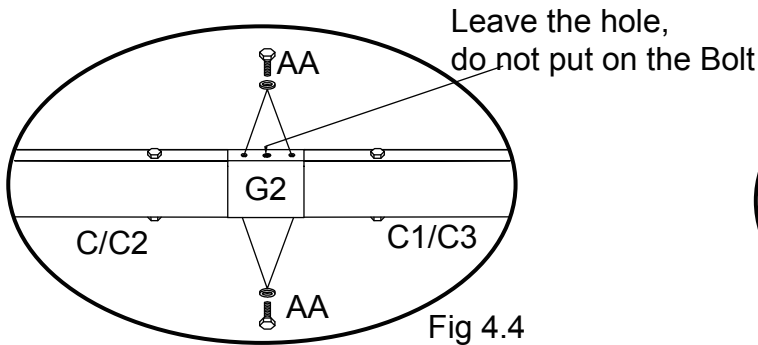
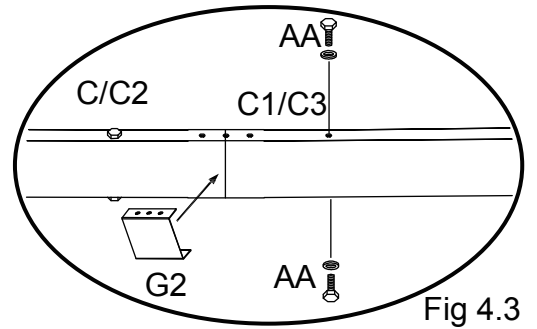
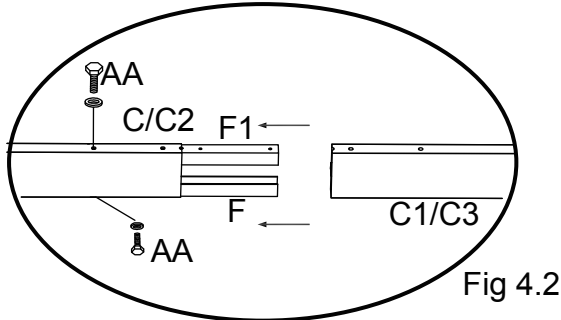
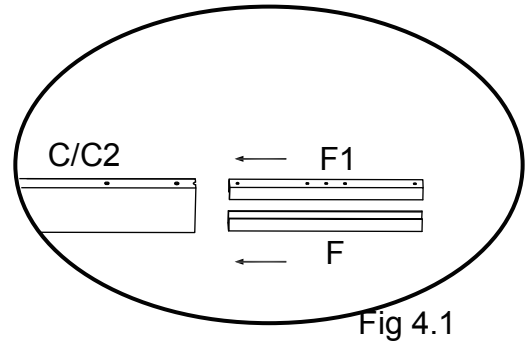
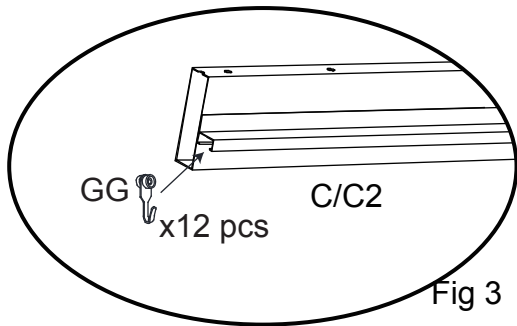
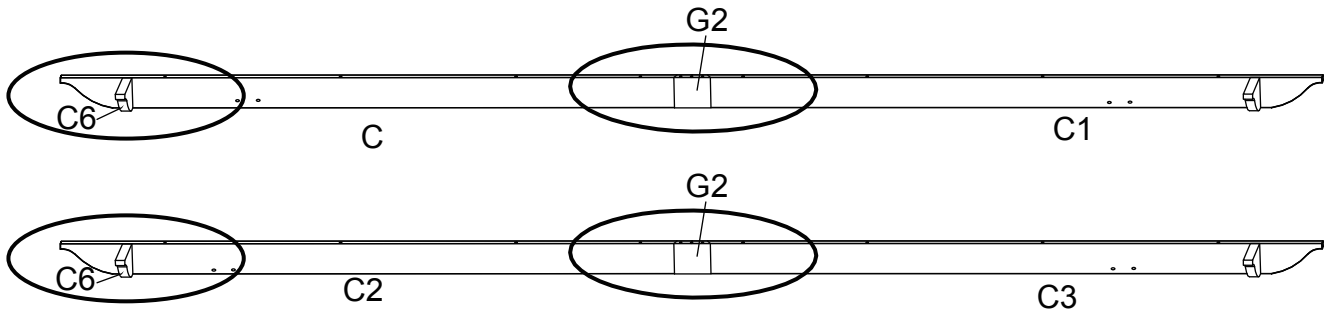

- 2.1. Slide the Hanger (GG) into the Mosquito net Rod above the Crossbeam Left (C/C2). See Fig 3.
- 2.2. Insert the Crossbeam Connector (F/F1) into the Crossbeam Left (C/C2), and connect them with Bolt (AA). Insert the Crossbeam Connector (F/F1) into the Crossbeam Right (C1/C3), and connect them with Bolt (AA). Connect the Crossbeam Shield (G2) to the Crossbeam (C/C1/C2/C3) with Bolt (AA). See Fig 4.1-4.4.
- 2.3. Connect the Decoration Cap (C6) to the Crossbeam (C/C2/C1/C3) with Bolt (DD). See Fig 5.

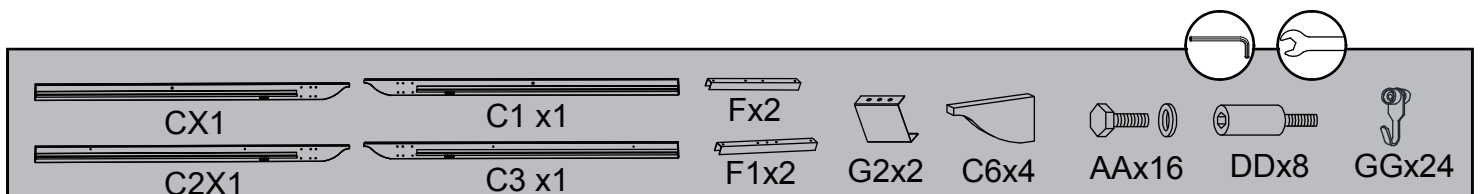

# Step 3

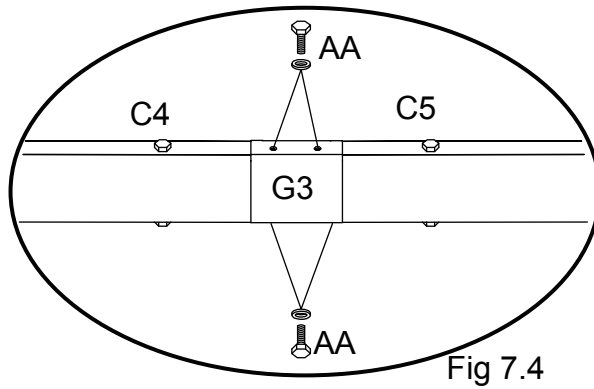
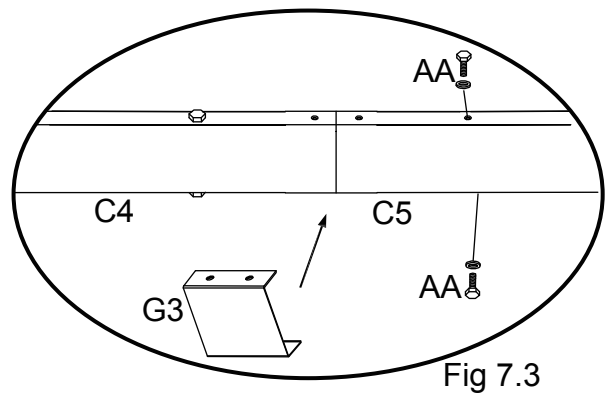
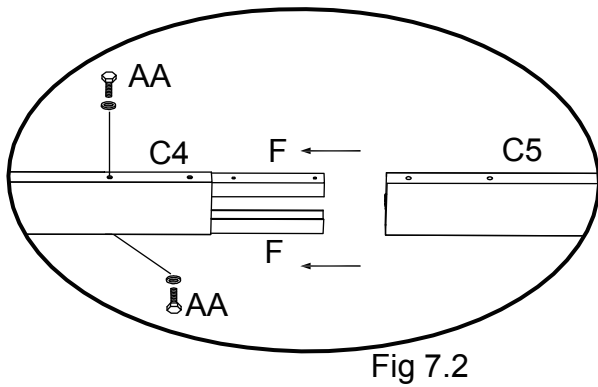
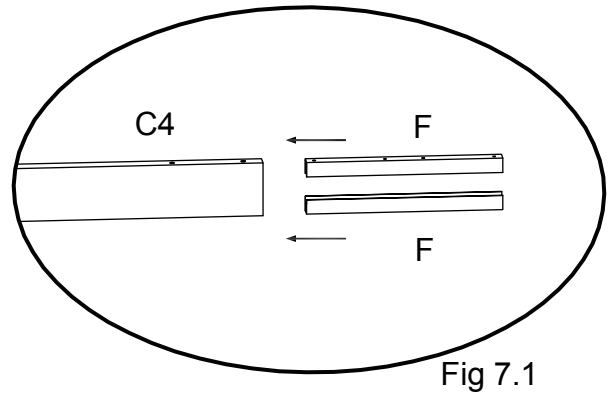
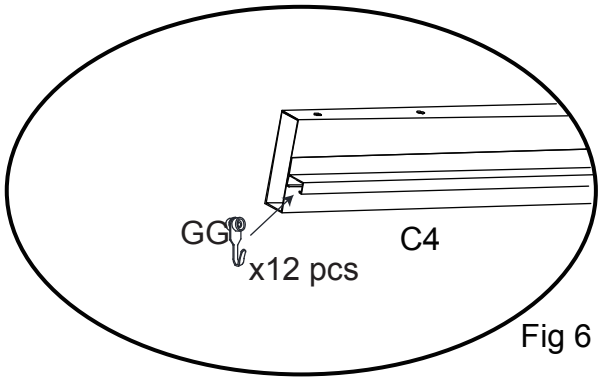
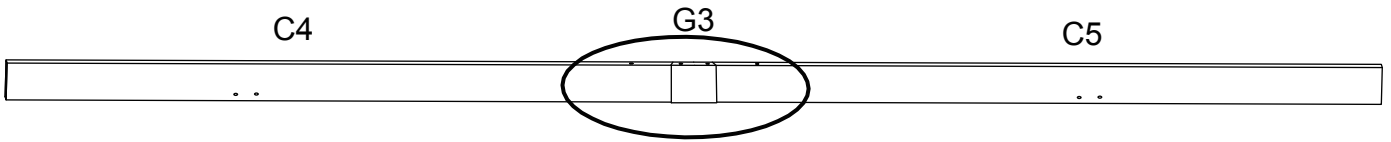

- 3.1. Slide the Hanger (GG) into the Mosquito net Rod above the Crossbeam (C4/C5). See Fig 6.  
 3.2. Insert the Crossbeam Connector (F) into the Crossbeam Left (C4) and connect them with Bolt (AA). Insert the Crossbeam Connector (F) into the Crossbeam Right (C5) and connect them with Bolt (AA). Connect the Crossbeam Shield (G3) and the Crossbeam (C4/C5) with Bolt (AA). See Fig 7.1-7.4.

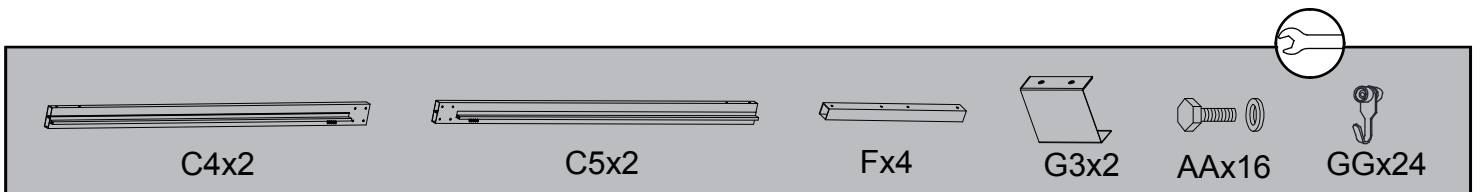

# Step 4

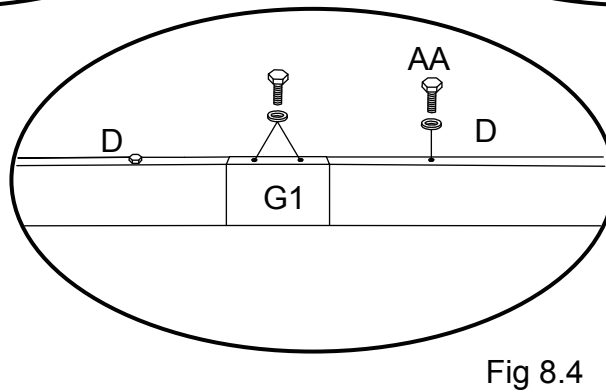
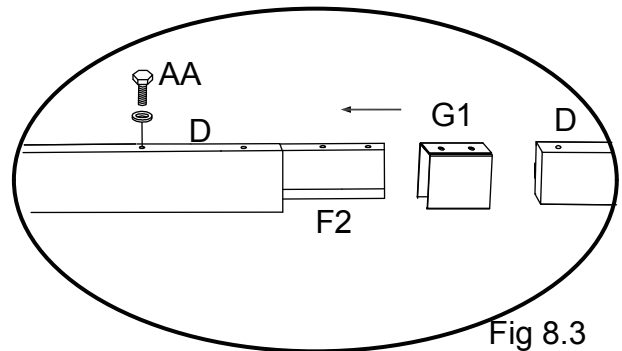
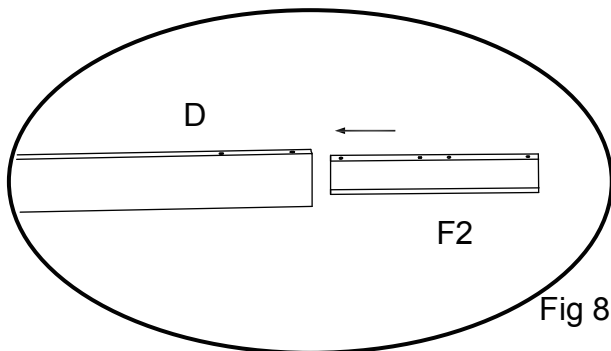
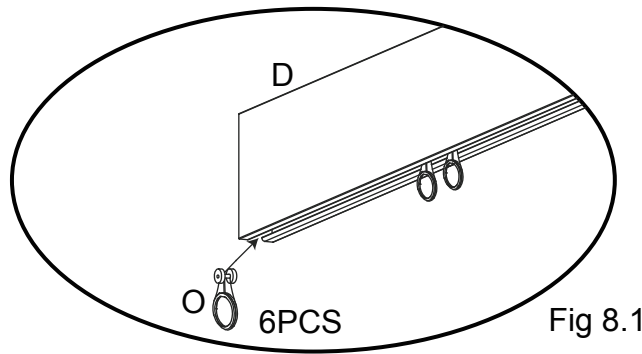
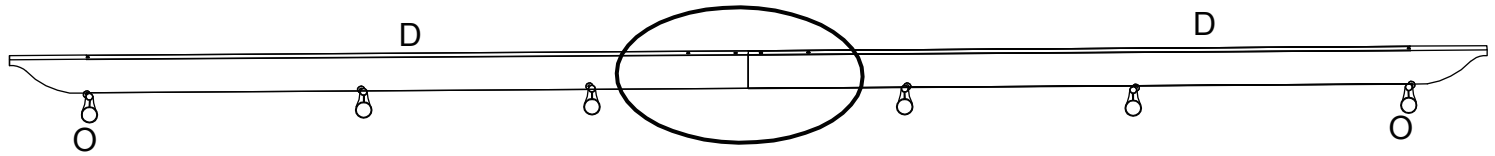

- 4.1. Insert the Pulley (O) into the Track Beam (D). See Fig 8.1.
- 4.2. Insert the Crossbeam Connector (F2) into the Track Beam (D) and connect them with Bolt (AA). Insert the Track Beam Shield (G1) into the Track Beam (D). Connect the Track Beam (D) and Track Beam Shield (G1) to the Crossbeam Connector (F2) with Bolt (AA). See Fig 8.2-8.4.

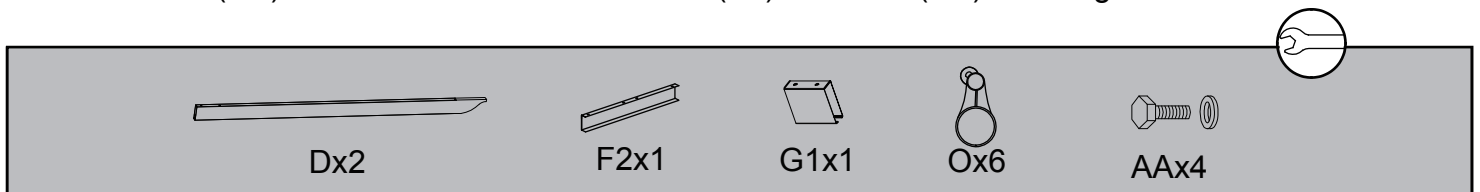

# Step 5

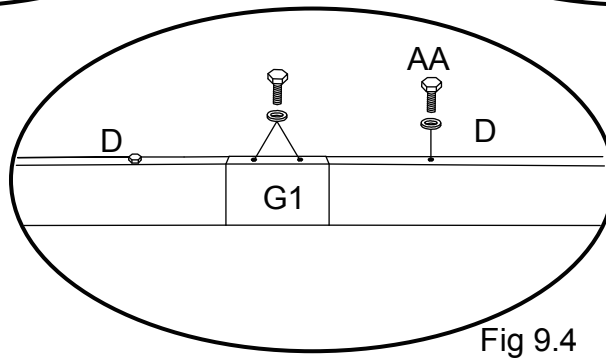
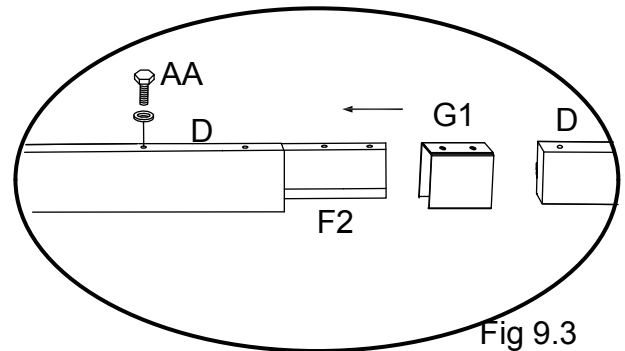
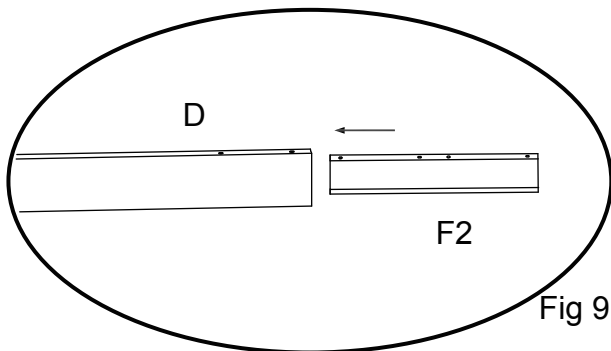
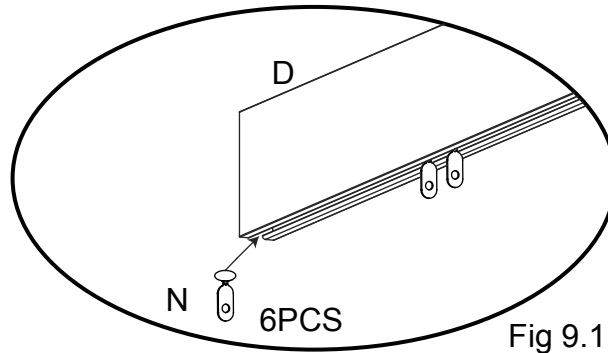
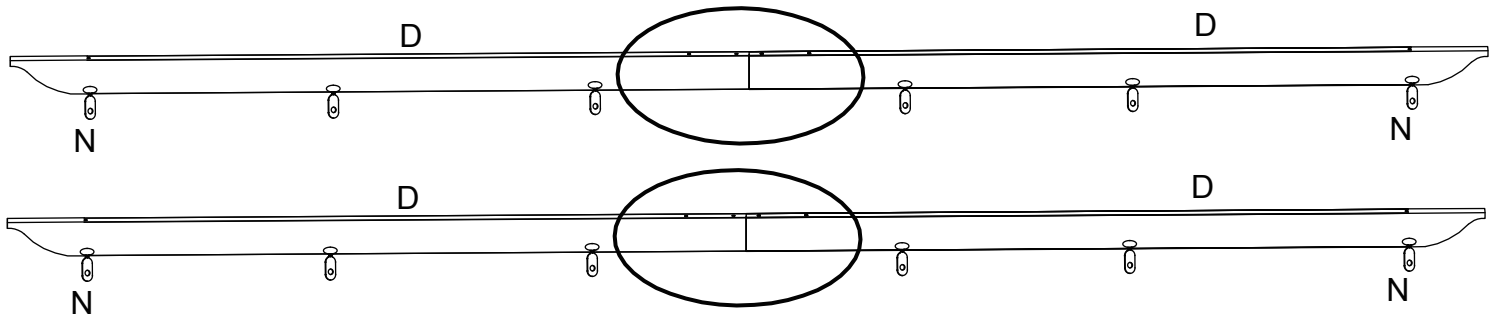

- 5.1. Insert the Pulley (N) into the Track Beam (D). See Fig 9.1.  
 5.2. Insert the Crossbeam Connector (F2) into the Track Beam (D) and connect them with Bolt (AA). Insert the Track Beam Shield (G1) into the Track Beam (D). Connect the Track Beam (D) and Track Beam Shield (G1) to the Crossbeam Connector (F2) with Bolt (AA). See Fig 9.2-9.4.

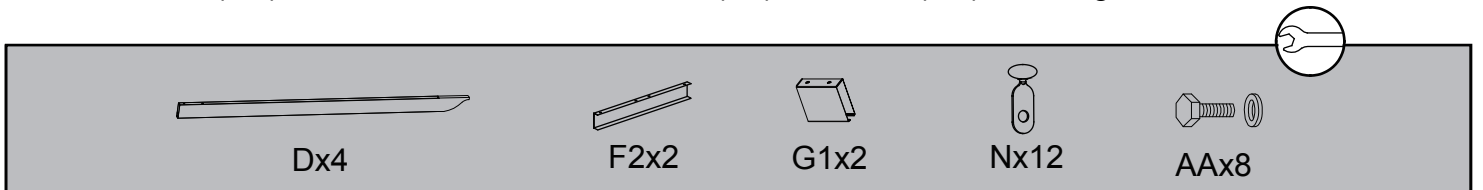

# Step 6

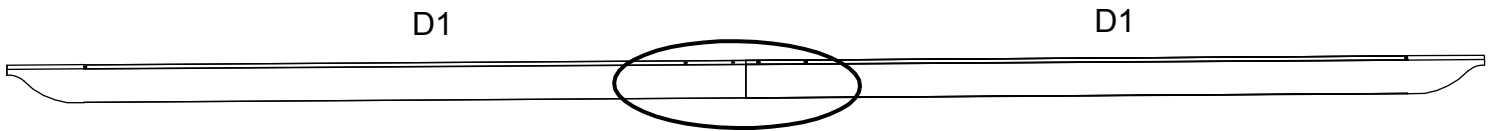

Fig 10.1-Fig 10.3

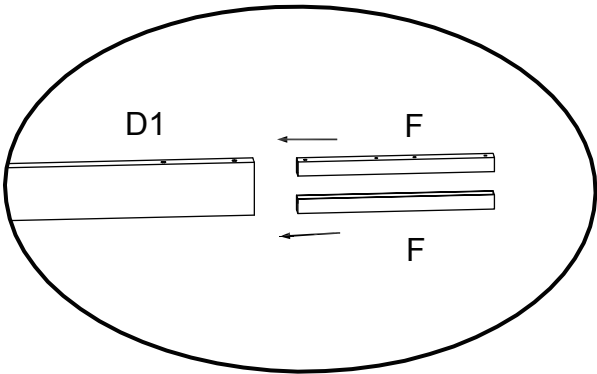

Fig 10.1

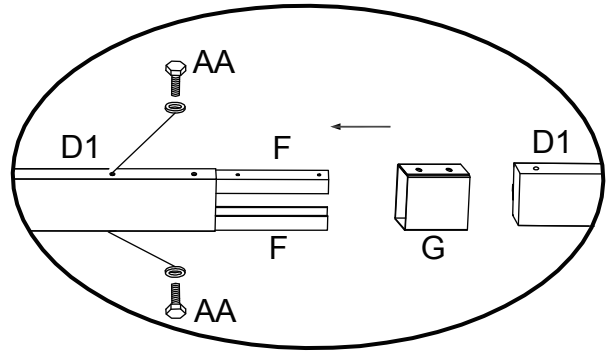

Fig 10.2

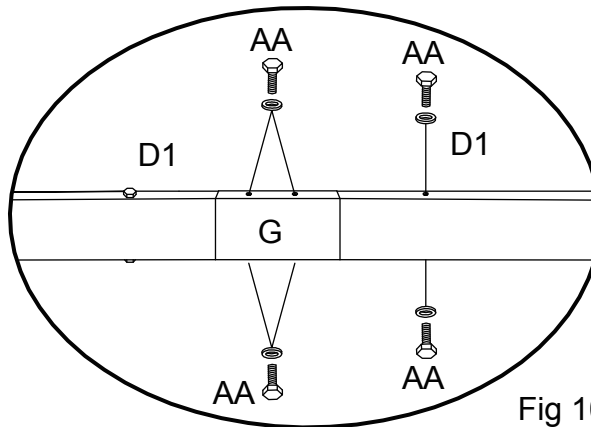
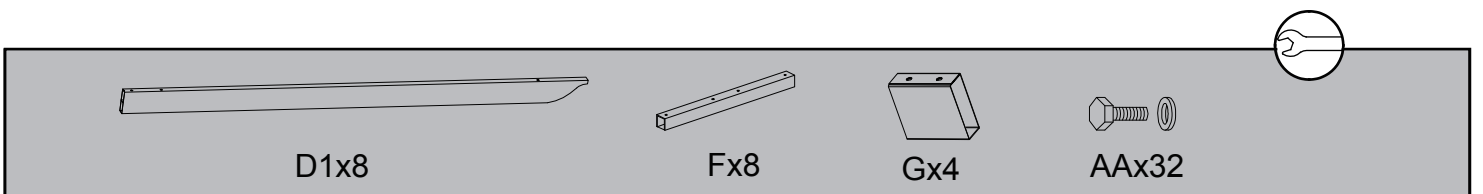

Fig 10.3

6. Insert the Crossbeam Connector (F) into the Top Crossbeam (D1) and connect them with Bolt(AA). Insert the Top Crossbeam Shield (G) into the Top Crossbeam (D1). Connect the Top Crossbeam (D1) / Top Crossbeam Shield (G) to the Crossbeam Connector (F) with Bolt (AA). See Fig10.1-10.3.



# Step 7

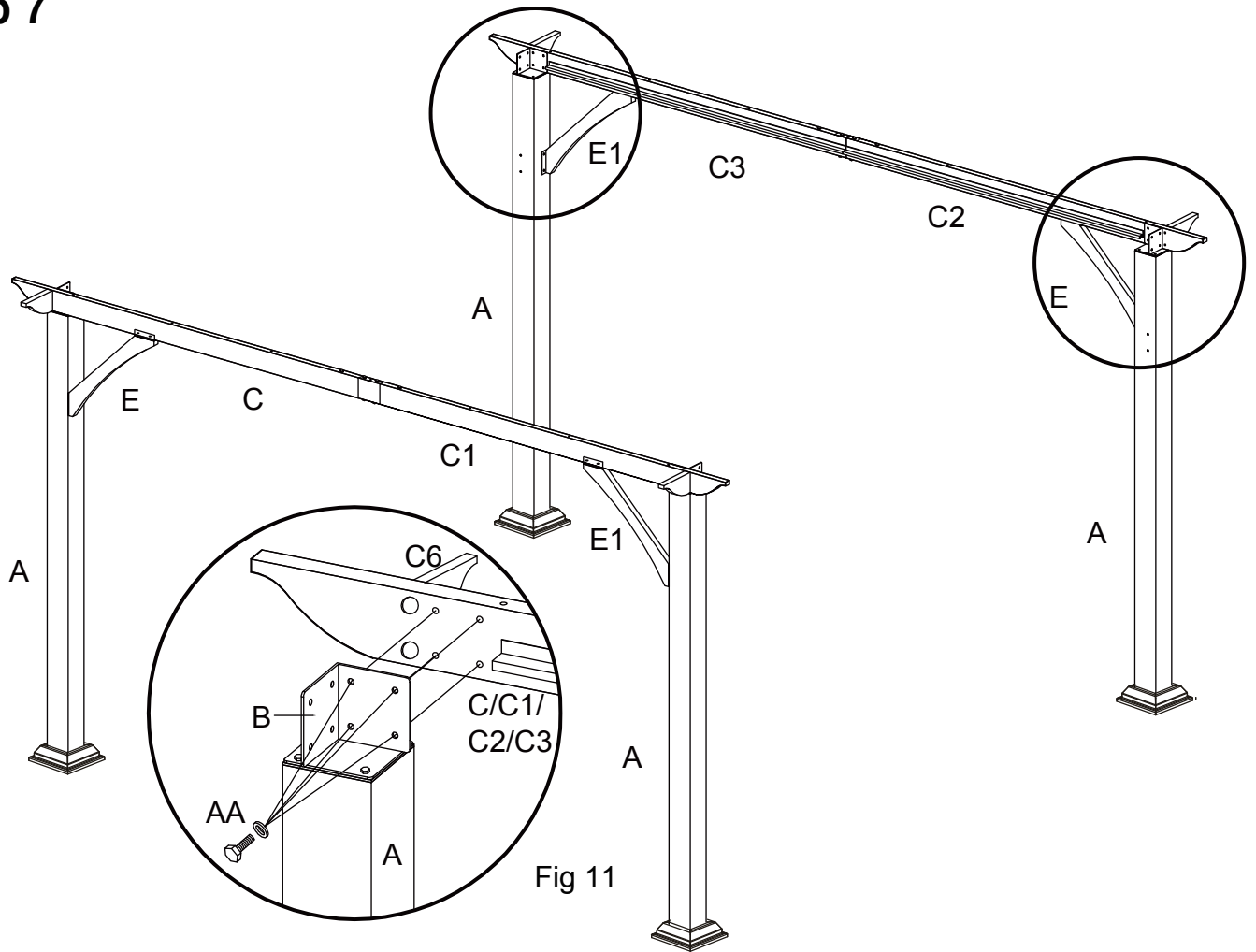

Fig 11

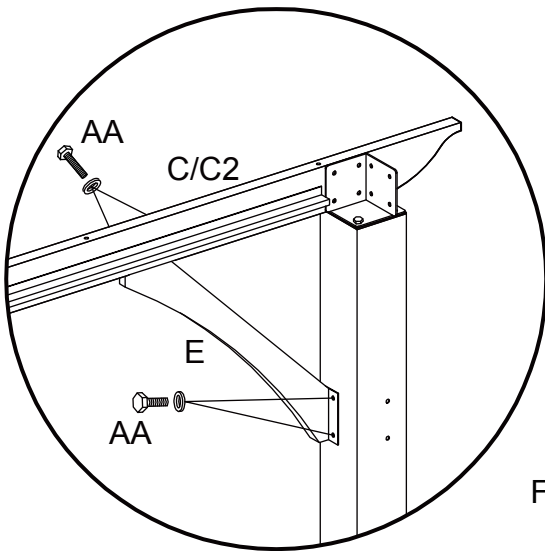

Fig 12.1

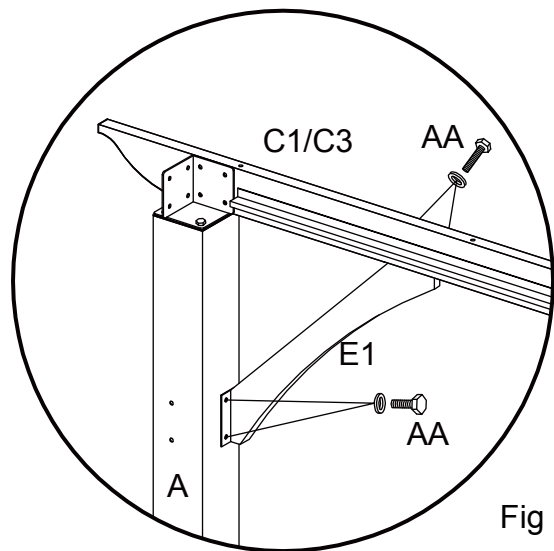
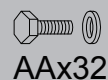
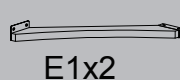
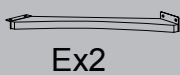

Fig 12.2

- 7.1. Connect the Post Corner (B) to the Crossbeam (C/C1/C2/C3) with Bolt (AA). See Fig.11.
- 7.2. Connect the Left Inclined Strut (E) to the Crossbeam Left (C/C2) and the Post (A) with Bolt (AA). See Fig 12.1.
- 7.3. Connect the Right Inclined Strut (E1) to the Crossbeam Right (C1/C3) and the Post (A) with Bolt (AA). See Fig 12.2.



# Step 8

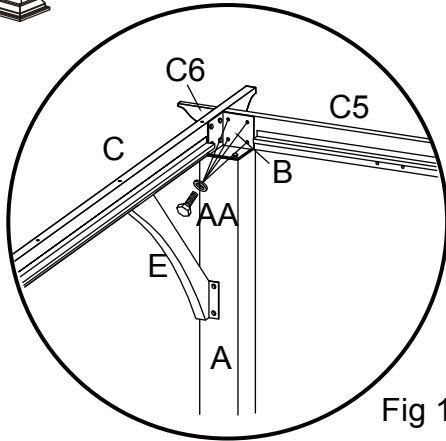
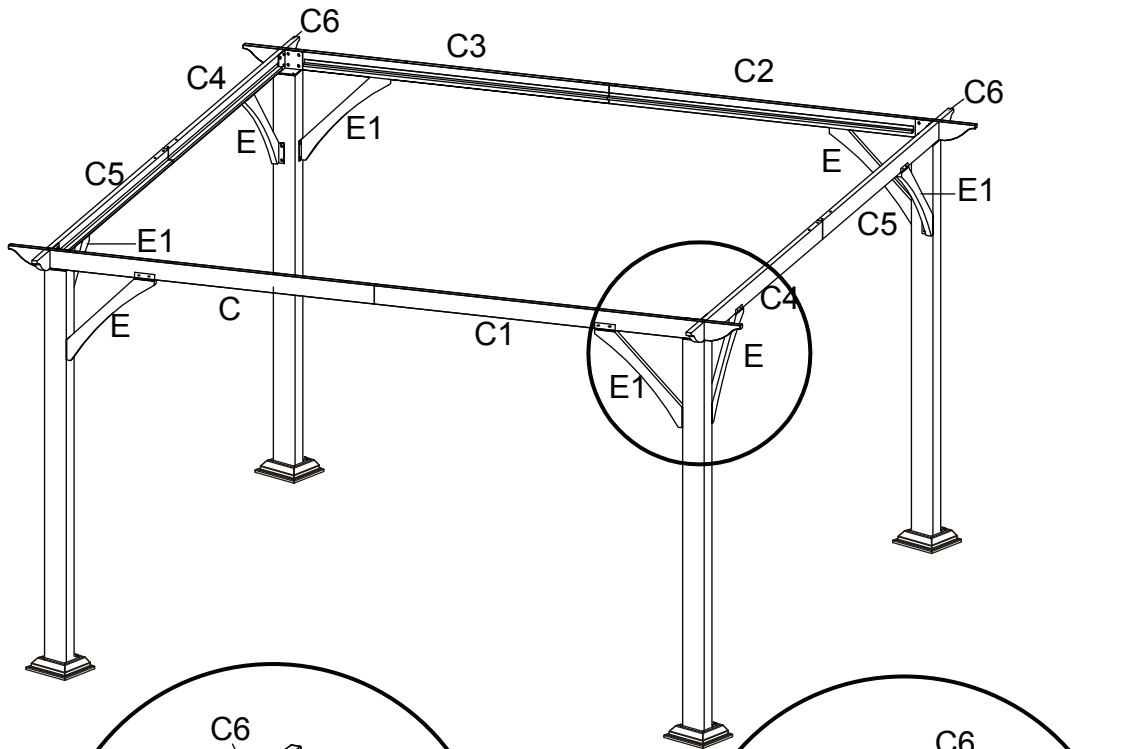

Fig 13.1

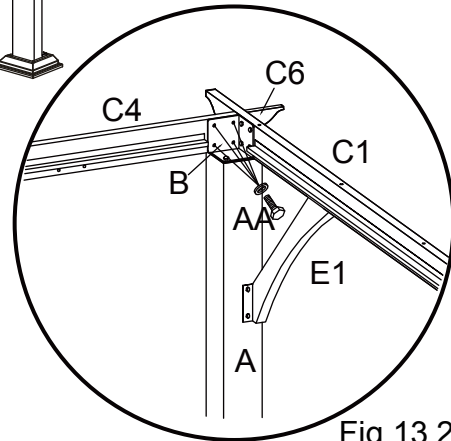

Fig 13.2

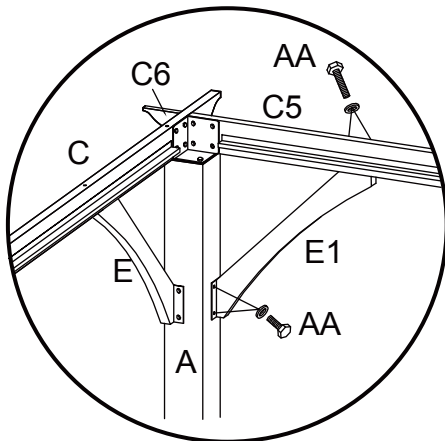

Fig 14.1

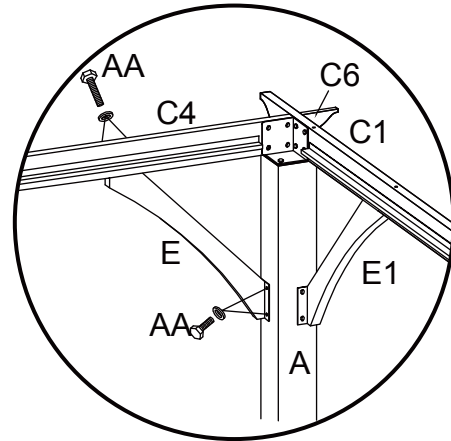
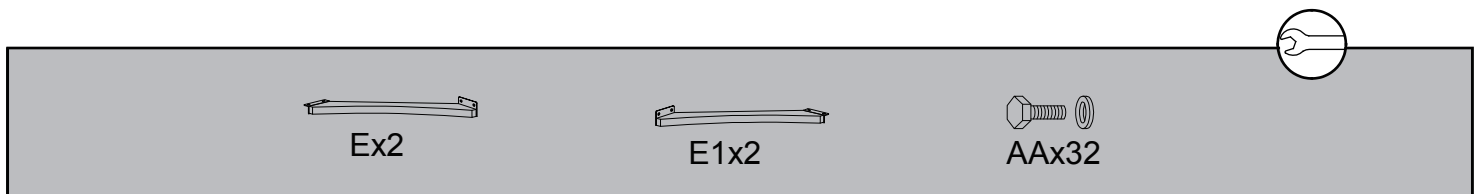

Fig 14.2

- 8.1. Connect the Post Corner (B) to the Crossbeam (C4/C5) with Bolt (AA). See Fig 13.1-13.2.  
 8.2. Connect the Right Inclined Strut (E1) to the Crossbeam Right (C5) and the Post (A) with Bolt (AA).  
 Connect the Left Inclined Strut (E) to the Crossbeam Left (C4) with Bolt (AA). See Fig 14.1-14.2.



# Step 9

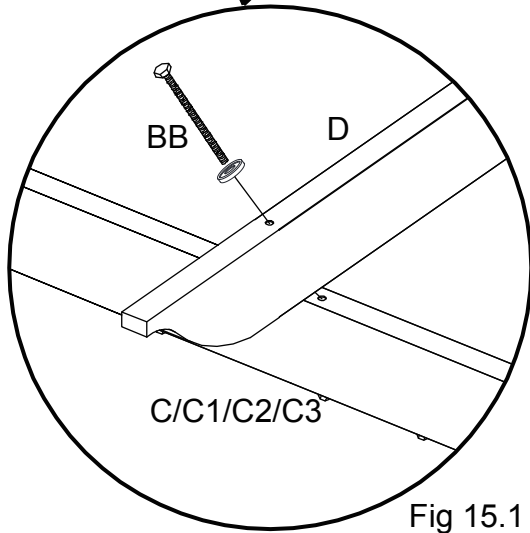
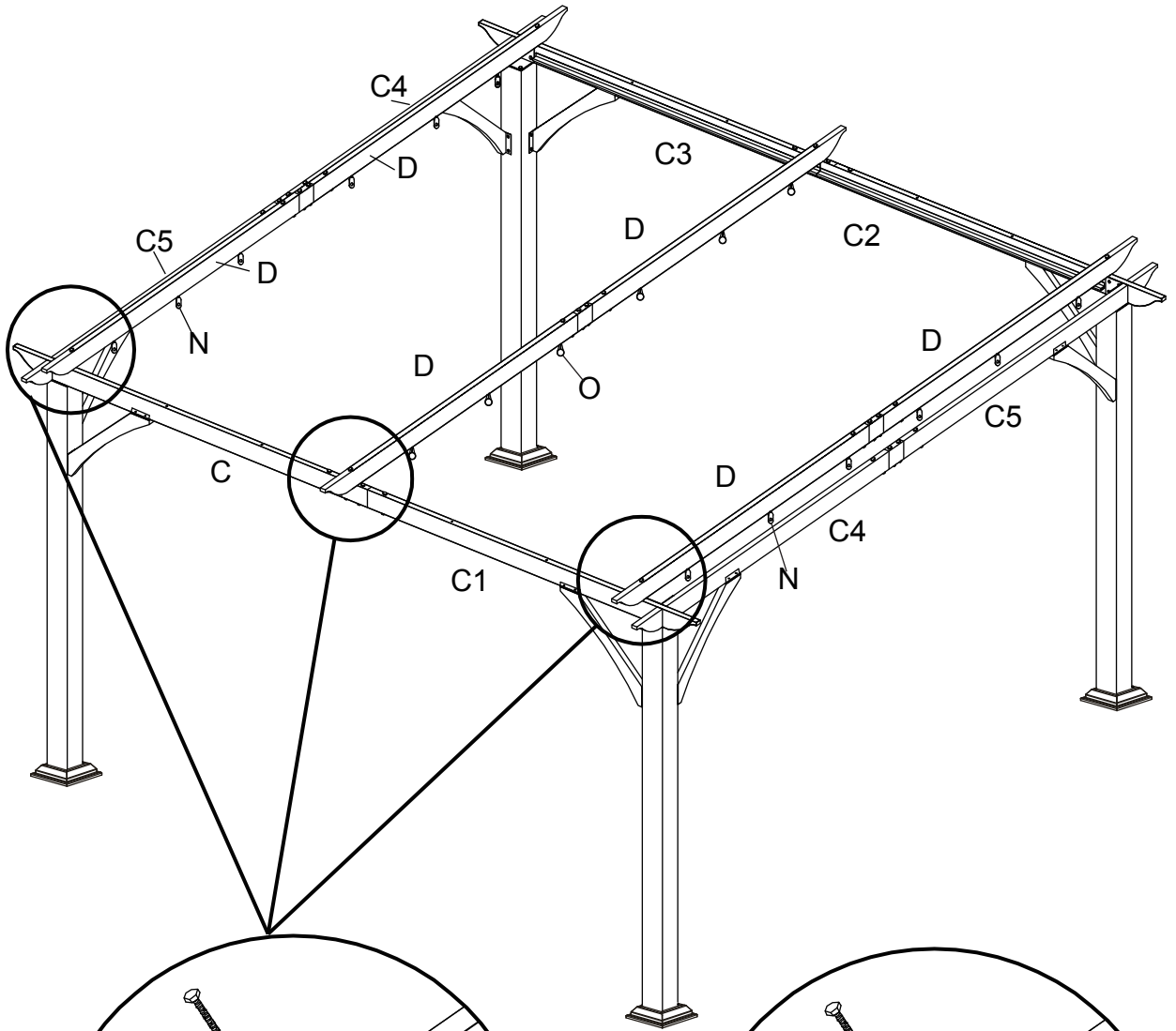

Fig 15.1

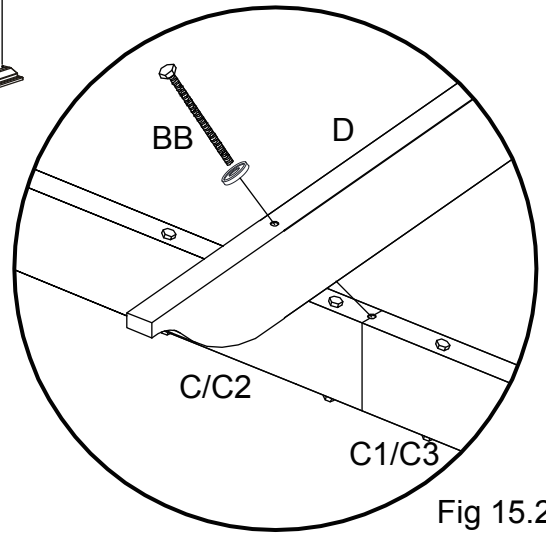
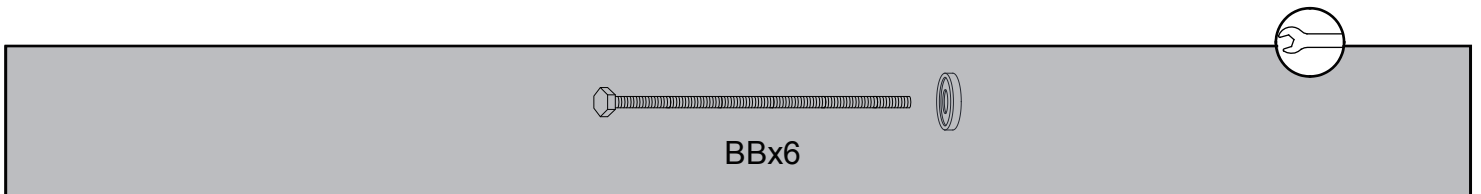
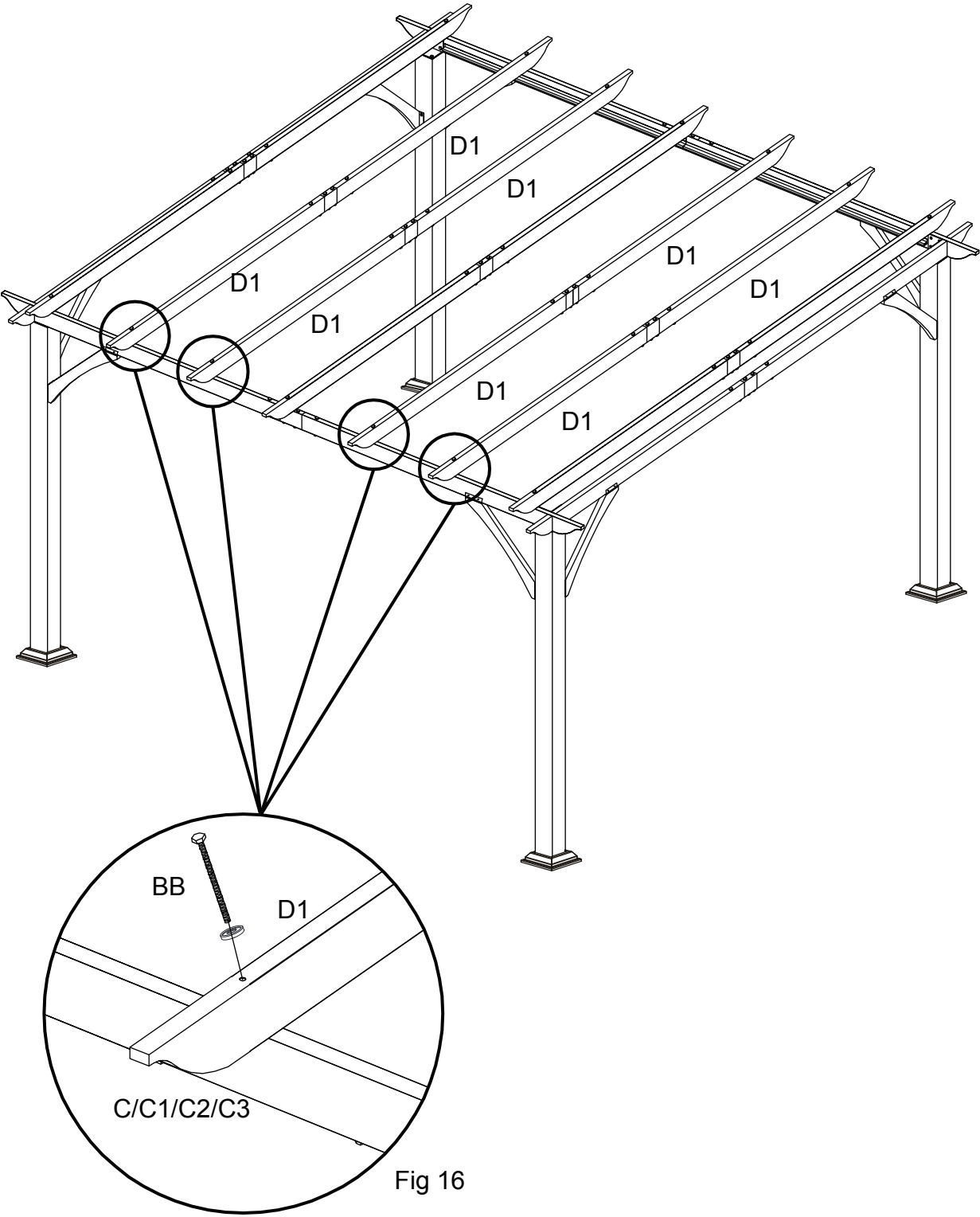

Fig 15.2

9. Connect the Track Beam (D) to the Crossbeam (C/C1/C2/C3) with Bolt (BB). See Fig 15.1-15.2.



# Step 10



10. Connect the Top Crossbeam (D1) to the Crossbeam (C/C1) with Bolt (BB). See Fig 16.

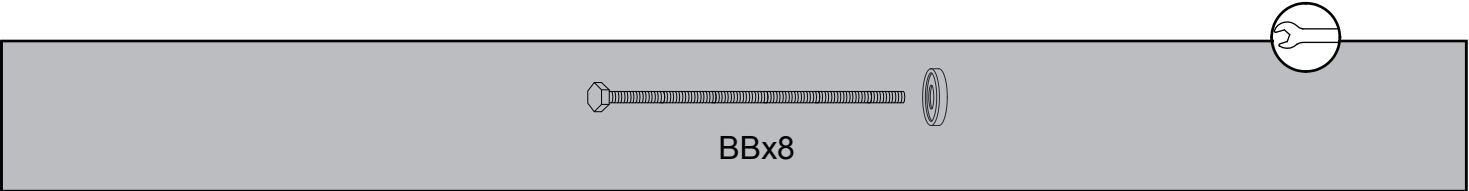

# Step 11

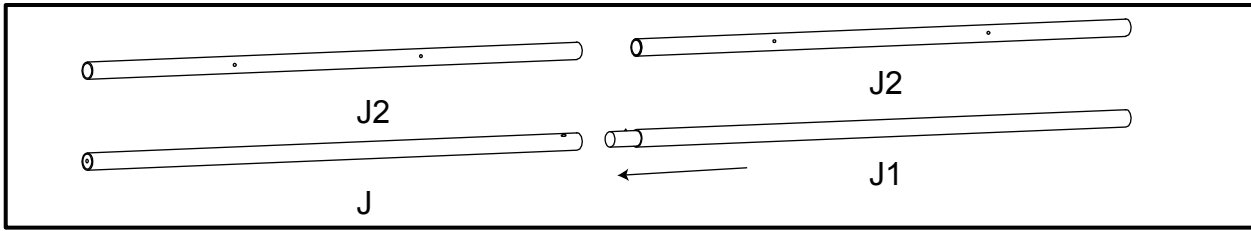

Fig 17

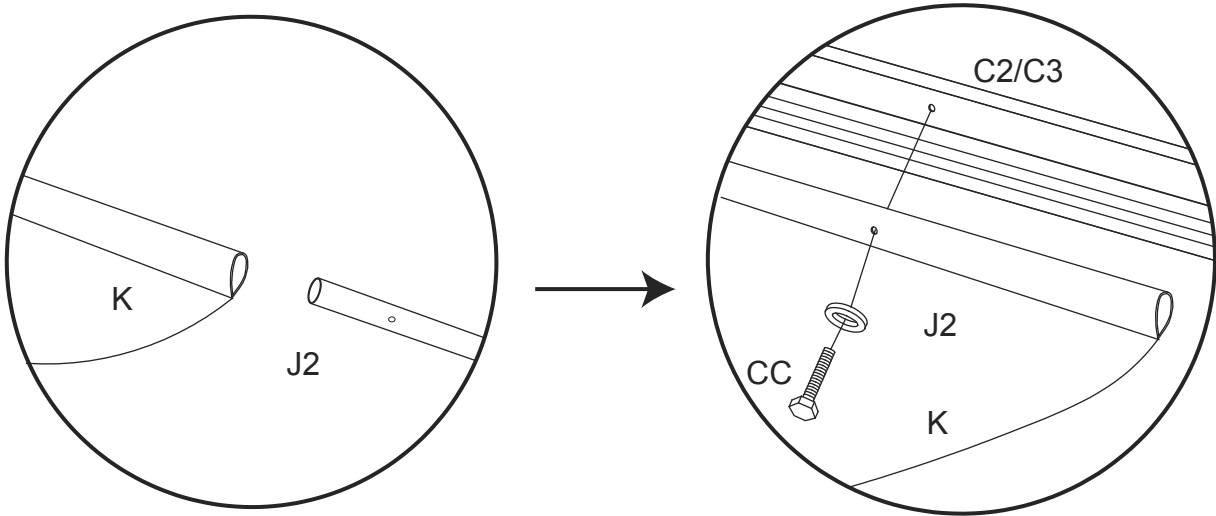
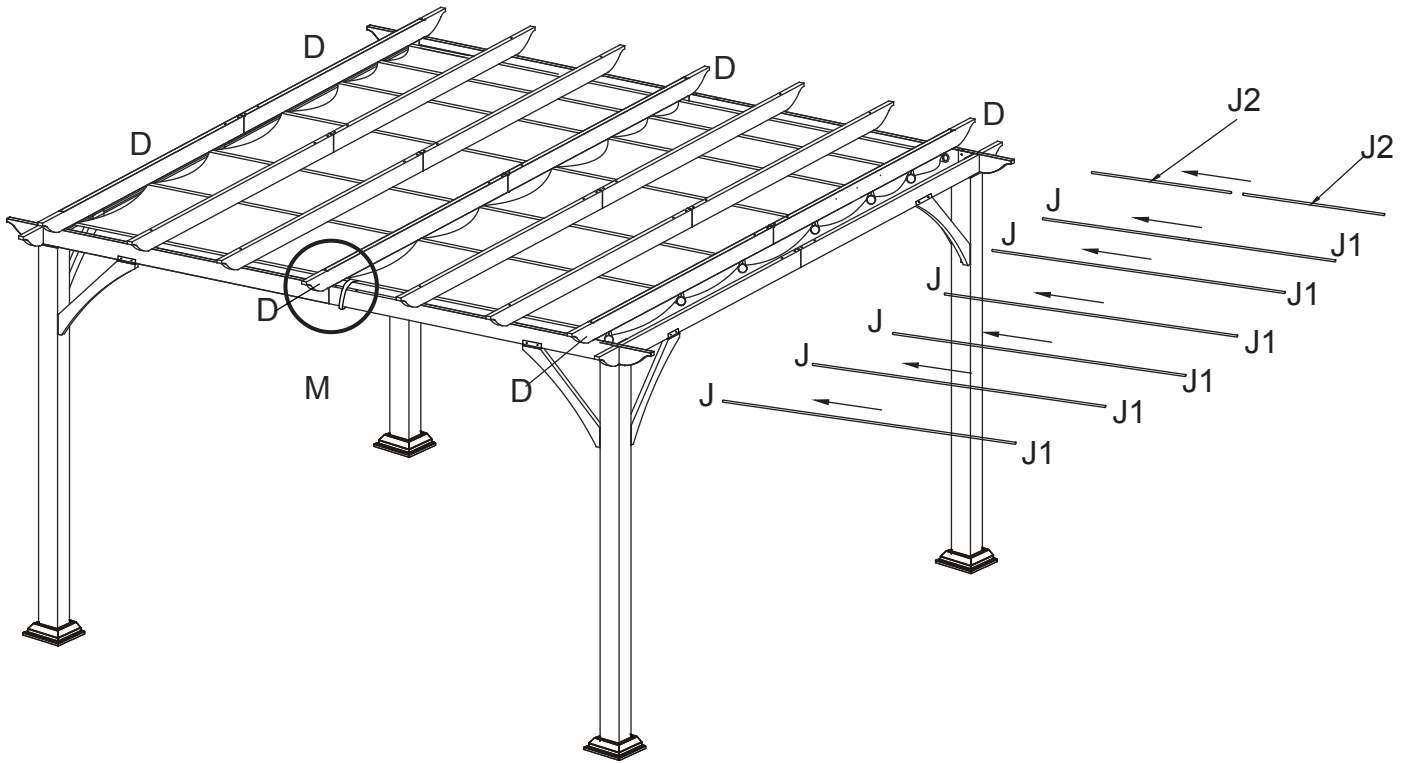

Fig 18

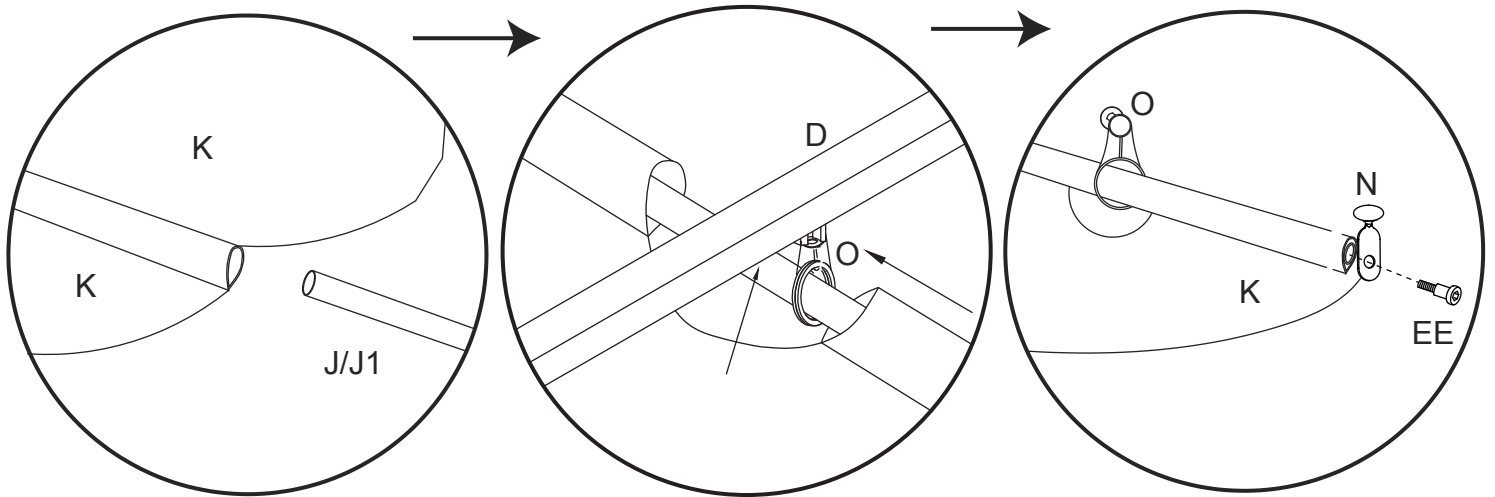

Fig 19

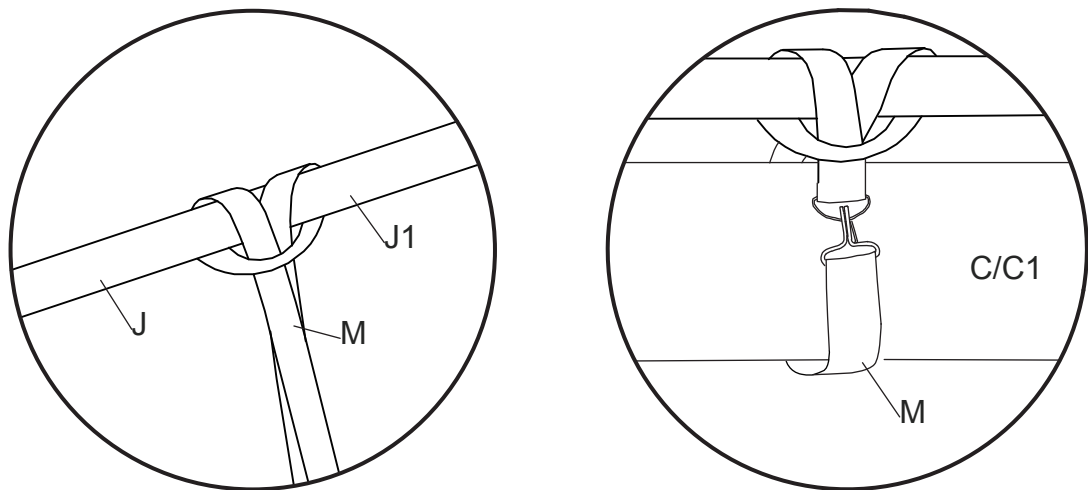
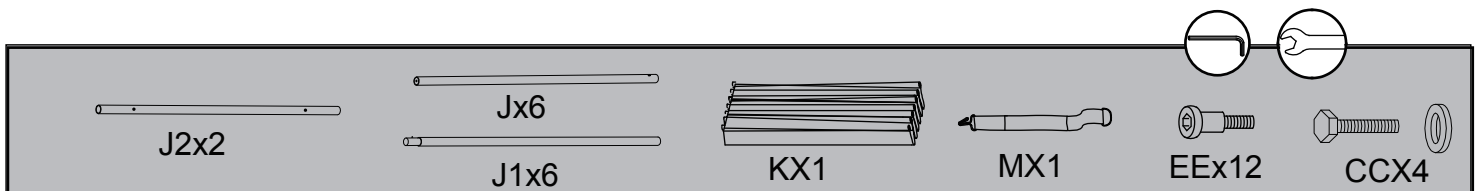

Fig 20

- 11.1. Connect the Left Cloth-inserted Pipe (J) to the Right Cloth-inserted Pipe (J1). See Fig17.
  - 11.2. Insert the Fixed Tube (J2) into the Roof (K), then connect them to the Crossbeam (C2/C3) with Bolt (CC). See Fig18.
  - 11.3. Insert the Left Cloth-inserted Pipe (J) and the Right Cloth-inserted (J1) into the Roof (K). Connect the Pulley (N) to the Cloth-inserted Pipe (J/J1) with the Bolt (EE) respectively. Connect the remaining Cloth-inserted Pipes (J/J1) in the same way. See Fig19.
- Note:** The Fixed Tube (J/J1) must go through the middle of the Pulley (O).
- 11.4. Connect the Rope Loop (M) to the Left Cloth Pipe (J) and the Right Cloth Tube(J1). and make the hangers on the Rope Loop (M) go through the Crossbeam (C/C1) ,then hang it onto the D-shaped hangers. See Fig 20.



# Step 12

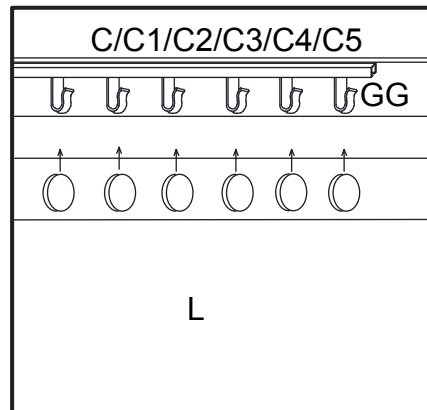
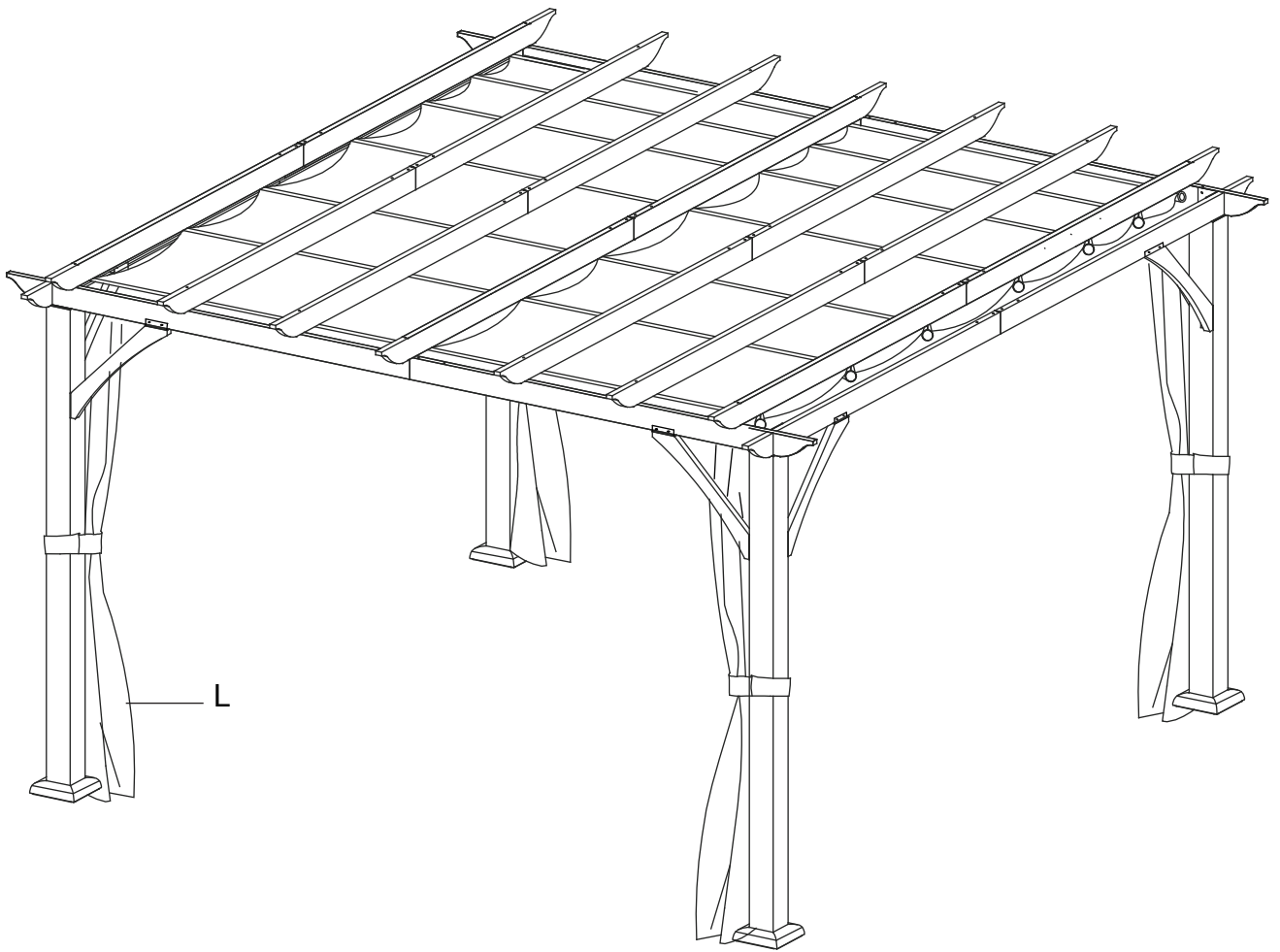
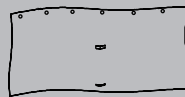

Fig 21

12. Hang the Sidewall (L) on the crossbeam using the Hanger (GG) preassembled on the crossbeam. See Fig 21.



LX4

# Step 13

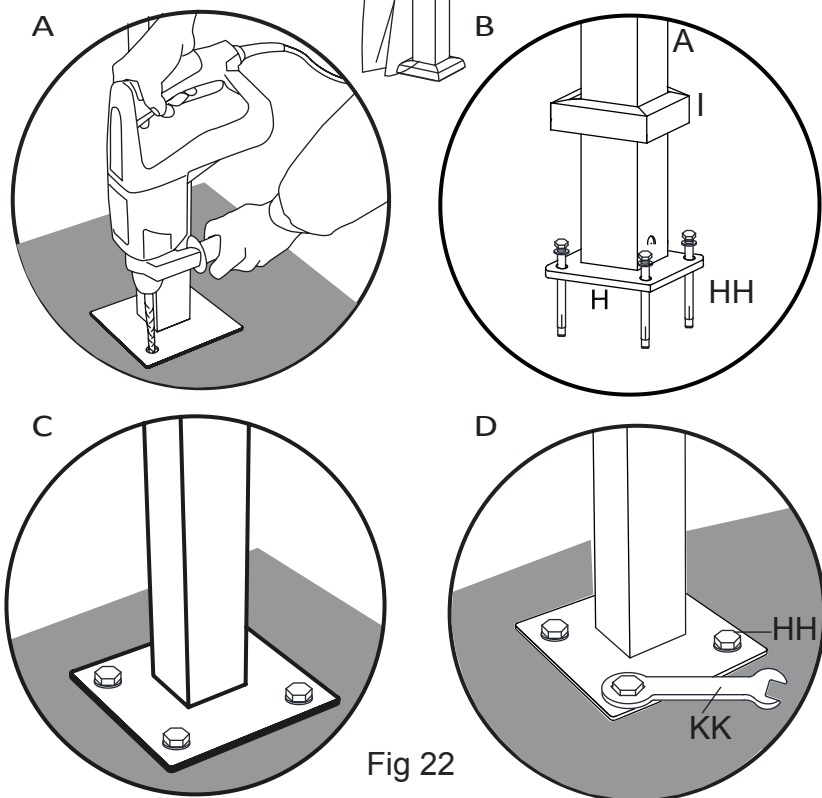
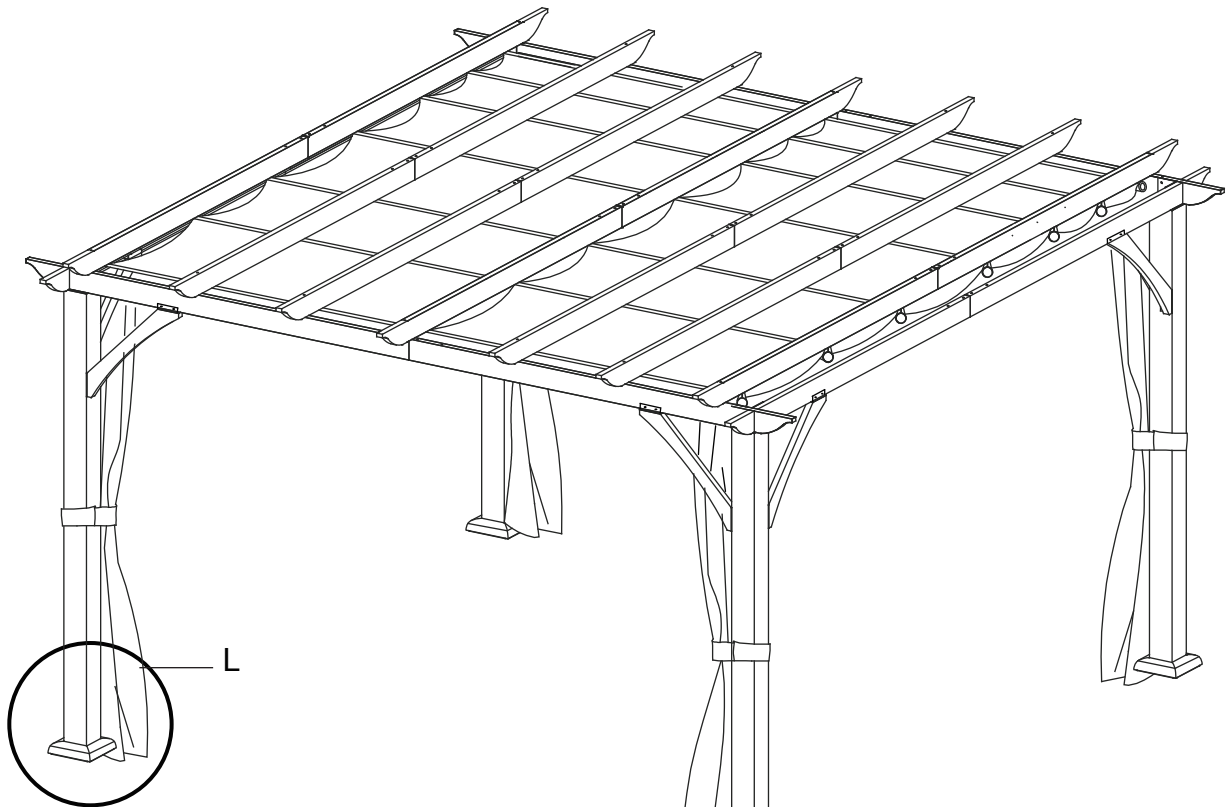
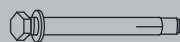
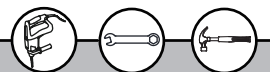

Fig 22

13. Using an electric concrete drill, drill holes into the concrete floor, corresponding to the holes in Base (H). Insert Expansion bolt (HH) into the holes and hammer into place, using a hammer. Fasten Expansion bolts (HH), make sure the base (H) are totally grounded. See Fig 22.



HHx16



## CARE AND MAINTENANCE

---

- For cleaning, use a mild detergent solution, rinse with water, and allow to air dry. Do not use acetone, abrasive, or other special detergents as they would be harmful to the product's finish.
- Due to the nature of steel, surface oxidation (rusting) will occur if this protective coating is scratched. This is a natural process. To minimize this condition, it is recommended that care be taken when assembling and handling the product in order to prevent the paint from being scratched.

---

This warranty does not affect your statutory rights. In case of any malfunction of your COSTCO product (failure, missing part, etc.), please contact one of our service technicians at our toll-free service line at 1-855-586-8118 from EST 9 AM to 5 PM, Monday to Friday.

Distributed by:  
Costco Wholesale Corporation  
P.O. Box 34535  
Seattle, WA 98124-1535  
USA  
1-800-774-2678  
www.costco.com

Costco Wholesale Australia Pty Ltd  
17-21 Parramatta Road  
Lidcombe NSW 2141  
Australia  
www.costco.com.au

Costco Wholesale Spain S.L.U.  
Polígono Empresarial Los Gavilanes  
C/ Agustín de Betancourt, 17  
28906 Getafe (Madrid) España  
NIF: B86509460  
900 111 155  
www.costco.es

Costco Wholesale Japan Ltd.  
3-1-4 Ikegami-Shincho  
Kawasaki-ku, Kawasaki-shi,  
Kanagawa 210-0832  
Japan 0570-200-800  
www.costco.co.jp

Costco Wholesale UK Ltd /  
Costco Online UK Ltd  
Hartspring Lane  
Watford, Herts  
WD25 8JS  
United Kingdom  
01923 213113  
www.costco.co.uk

Costco Wholesale Korea, Ltd.  
40, Iljik-ro  
Gwangmyeong-si  
Gyeonggi-do, 14347, Korea  
1899-9900  
www.costco.co.kr

Importado por:  
Importadora Primex S.A. de C.V.  
Blvd. Magnocentro No. 4  
San Fernando La Herradura  
Huixquilucan, Estado de México  
C.P. 52765  
RFC: IPR-930907-S70  
(55)-5246-5500  
www.costco.com.mx

Costco France  
1 avenue de Bréhat  
91140 Villebon-sur-Yvette  
France  
01 80 45 01 10  
www.costco.fr

Costco Wholesale New Zealand Limited  
2 Gunton Drive  
Westgate  
Auckland 0814  
New Zealand

Costco (China) Investment Co., Ltd.  
Room 1003, Block 2, 2388 Xiupu Road,  
Pudong New Area, Shanghai  
China 201315  
+86-21-6257-7065

Costco Wholesale Canada Ltd.\*  
415 W. Hunt Club Road  
Ottawa, Ontario  
K2E 1C5, Canada  
1-800-463-3783  
www.costco.ca

Costco Wholesale Sweden AB  
Saluvägen 5  
187 66 Täby  
Sweden

\* faisant affaire au Québec sous  
le nom les Entrepôts Costco

Costco Wholesale Iceland ehf.  
Kauptún 3-7, 210 Gardabaer  
Iceland  
www.costco.is

---

MADE IN CHINA  
FABRIQUÉ EN CHINE  
HECHO EN CHINA